

CFE-41 Protocol Converter and Communications Hub



SystemCORP Pty Ltd



CFE-41

Description

The communications processor module CFE-41 is a powerful 96 MHz embedded real-time processor system integrating all peripheral interfaces such as serial ports for IED integration, 10/100 Base-T Ethernet port supporting the IEC 61850 standard and a USB port for configuration and diagnostics. Application software is stored in the integrated Flash memory on the SC143 hybrid chip.

The embedded software controls and manages:

- System database
- User application and software tasks
- SCADA client and server protocol applications such as:
 - IEC 61850
 - IEC 6870-5-101/104 server
 - IEC 6870-5-103 client
 - DNP 3.0 client/server
 - Modbus client
- Digital inputs/outputs (optional)
- IEC 61131 built-in programmable logic control applications

The CFE-41 has four on-board serial communication ports. Three ports are used for IED integration using various SCADA communication protocols. One port is reserved as system console interface.

IEDs are integrated using client or so-called 'sub-master' protocol applications collecting all data from IEDs, which are stored in the system database and redistributed to server or slave SCADA protocol applications. Database information can be processed by IEC 61131 user software applications.

A type B USB port is available for diagnostics and configuration.

LEDs on the front panel allow monitoring data traffic on all communication channels and the module status.

For simple monitoring and control applications, 2 digital inputs and outputs can optionally be provided.

Key Features

- ✓ IEC 61850 Server/Client Functionality
- ✓ SC143 Microprocessor, 96 MHz
- ✓ 8 MB Flash Memory and 8 MB RAM
- ✓ 1 Ethernet Port - 10/100 MByte
- ✓ 4 Serial Ports
- ✓ 1 USB Interface
- ✓ Process LED Indications for
 - Run/Fail and Power
 - Ethernet Activities
 - Serial Port Activities
- ✓ Fully integrated WEB Services
- ✓ IEC 61131 Programmable Logic Controller
- ✓ Optional:
 - 2 x Digital Inputs
 - 2 x Digital Outputs
 - Real Time Clock (Battery Backup)

System Configuration

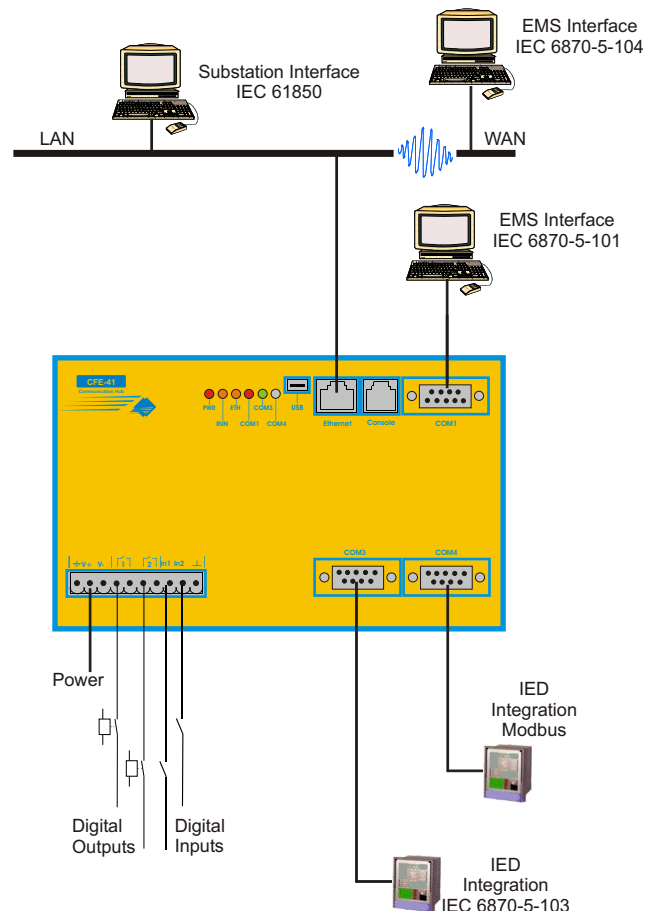

Module Block Diagram

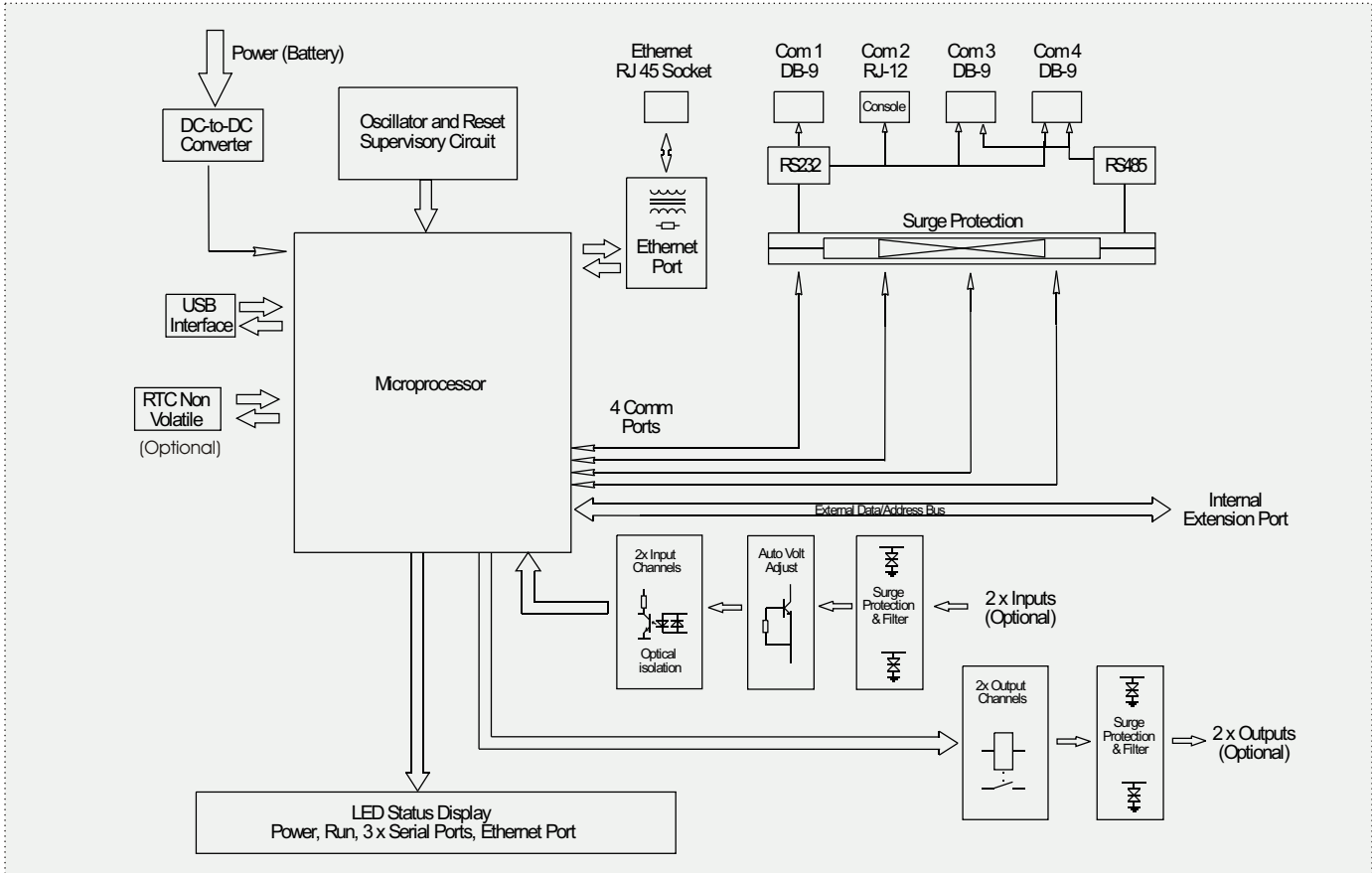

Technical Specification

Processor	Beck SC143, 96MHz
Memory	8 MB On-board Flash ROM 8 MB On-board RAM
Communication Ports	1 Ethernet Ports 10/100 Base T 3 standard serial ports & 1 Console Port 1 USB Type B for configuration/diagnostics
Inputs and Outputs (Optional)	2x input 12-110Vdc, 5kv isolated 2x output contacts @ 240Vac/30Vdc 6 amp, 4kv isolated
Diagnostic LEDs	Module Power Run/Fail Ethernet 1 Link/Active Serial Comm Port 1, 3, 4 TX/RX
Physical Dimensions	CFE-41 197x113x49 mm, 480 grams
Mounting	DIN Rail or Panel Mount
Power Supply	18 - 72 Vdc 95 - 160 Vdc 90 - 260 Vac
Power Consumption	max. 5 Watts

Operating Temperature

-10 C to +55 C

Technical Compliance

Electrical

IEC 61000-4-2	Electrostatic Discharge
IEC 61000-4-3	Radiated Field Disturbance
IEC 61000-4-4	Fast Transients
IEC 61000-4-5	Surge Immunity
IEC 61000-4-6	Conducted RF Disturbance
IEC 61000-4-8	Power Frequency Magnetic Field
IEC 61000-4-12	Damped Oscillatory Waves
CISPR 22	Interference Field Strength

Environmental

IEC 60068-2-2	Operating Temperature
IEC 60068-2-78	Steady Relative Humidity
IEC 60068-2-30	Cyclic Relative Humidity

Mechanical

IEC 60068-2-6	Vibration Response and Endurance
IEC 60068-2-27	Shock Response and Endurance

Configuration and Diagnostics

SystemCORP WebCAN Designer