

TRIP CIRCUITS AND SUPERVISION

AND CORRECT CIRCUITRY

E-mail: rgh@rodhughesconsulting.com
Office: +61 8 7127 6357
Mobile: +61 419 845 253
Web: www.rodhughesconsulting.com
Skype: rodhughes-consult
LinkedIn: <https://www.linkedin.com/in/rodneighughes>
Address: PO Box 757
Blackwood
SA 5051
Australia
A.B.N. 64 137 442 089



General Trip Circuit

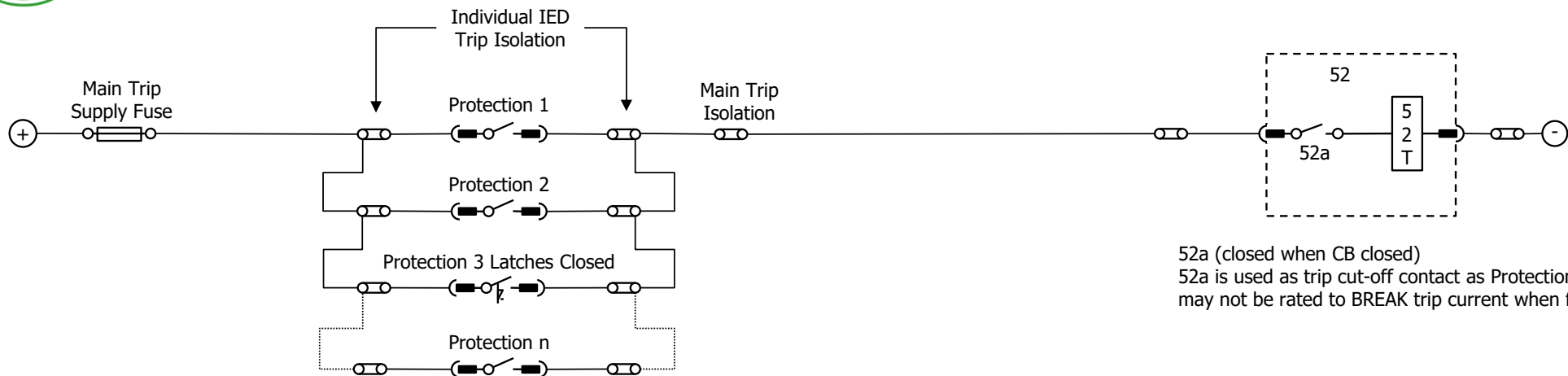

52a (closed when CB closed)
52a is used as trip cut-off contact as Protection contacts may not be rated to BREAK trip current when fault is cleared

Protections contacts are generally self-resetting contacts.
When the fault condition is cleared by the CB opening, the protection function resets and its contact opens.

Protection 3 is shown with Latched Trip contact
Consider Protection 3 operates but CB fails to clear the fault as a CB Fail condition.
CB Fail should trip upstream breaker, but Protection 3 remains operated and 52a remains closed.
As such, 52T trip coil is permanently energized and may burn out!

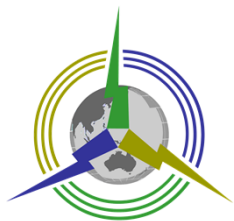

Lockout Close Circuits

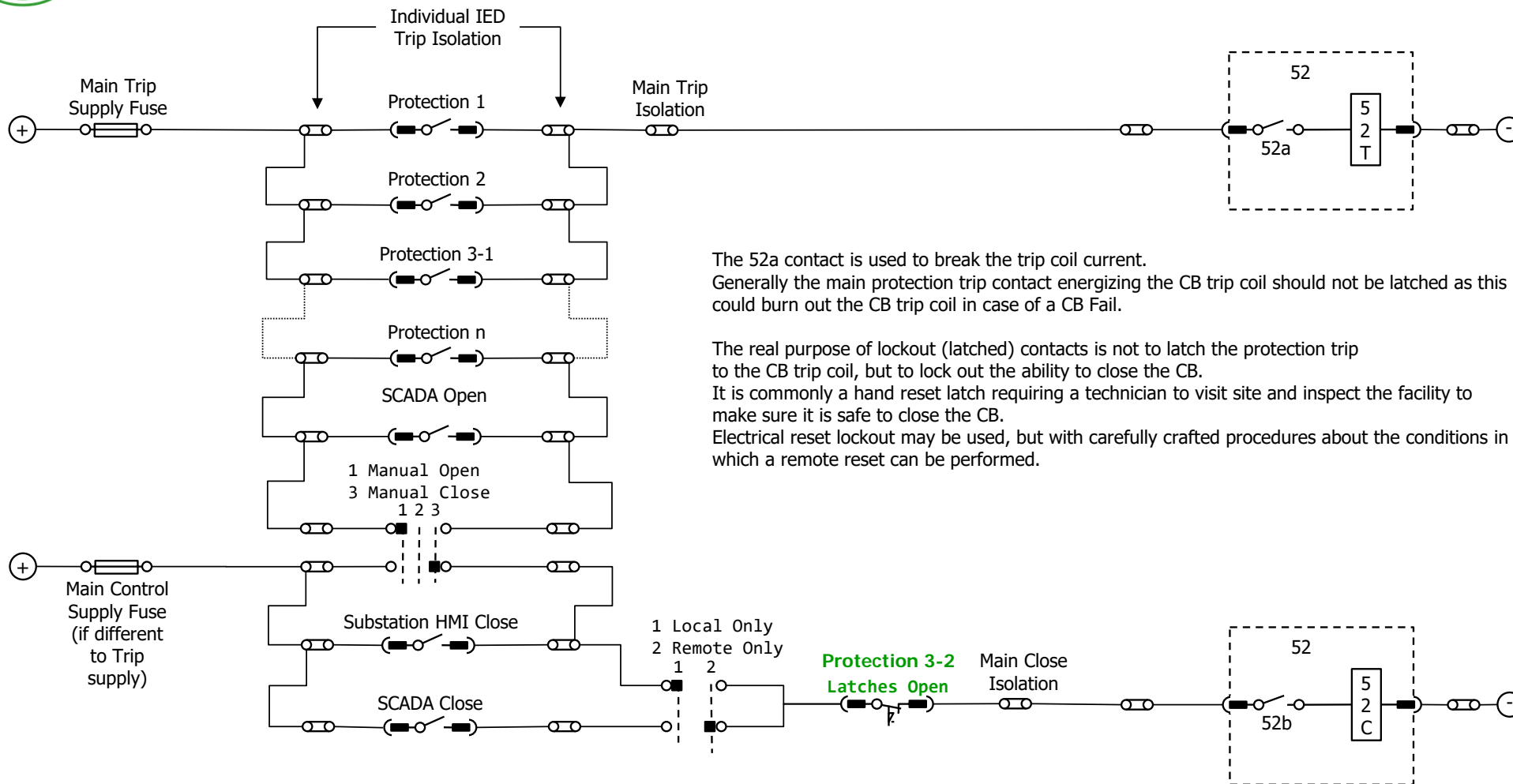

The 52a contact is used to break the trip coil current. Generally the main protection trip contact energizing the CB trip coil should not be latched as this could burn out the CB trip coil in case of a CB Fail.

The real purpose of lockout (latched) contacts is not to latch the protection trip to the CB trip coil, but to lock out the ability to close the CB. It is commonly a hand reset latch requiring a technician to visit site and inspect the facility to make sure it is safe to close the CB. Electrical reset lockout may be used, but with carefully crafted procedures about the conditions in which a remote reset can be performed.

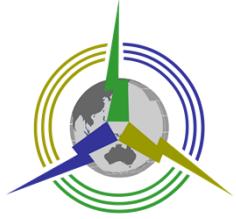

Trip Supervision

- ✦ Supervision must not cause CB trip
- ✦ Must cater for CB open/closed change over time
- ✦ DC undervoltage monitor
- ✦ CB connection monitor
 - ★ Practical for withdrawable switchgear
 - ★ Verify plug has connected
 - ★ Does not verify 52T “pin” in connector is made

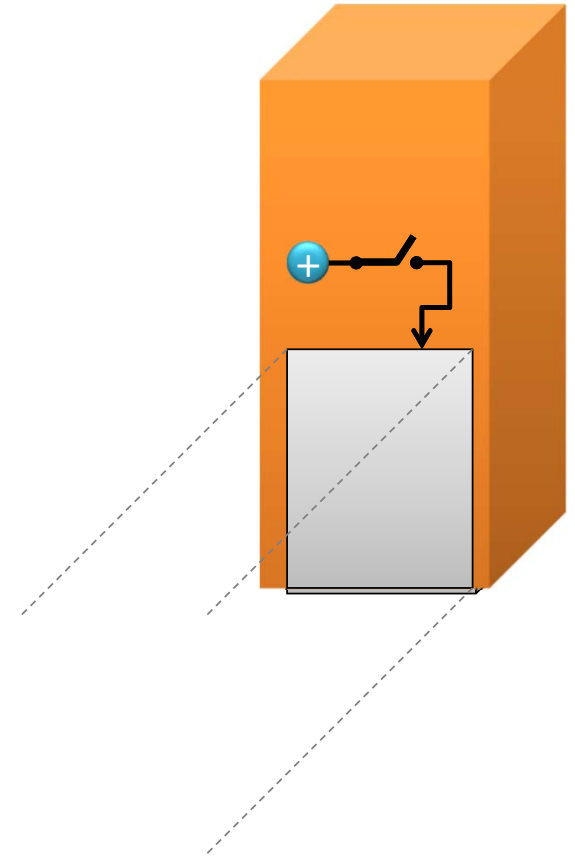

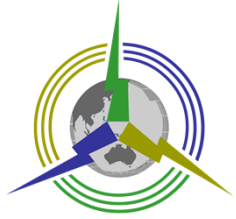

Connection Monitor

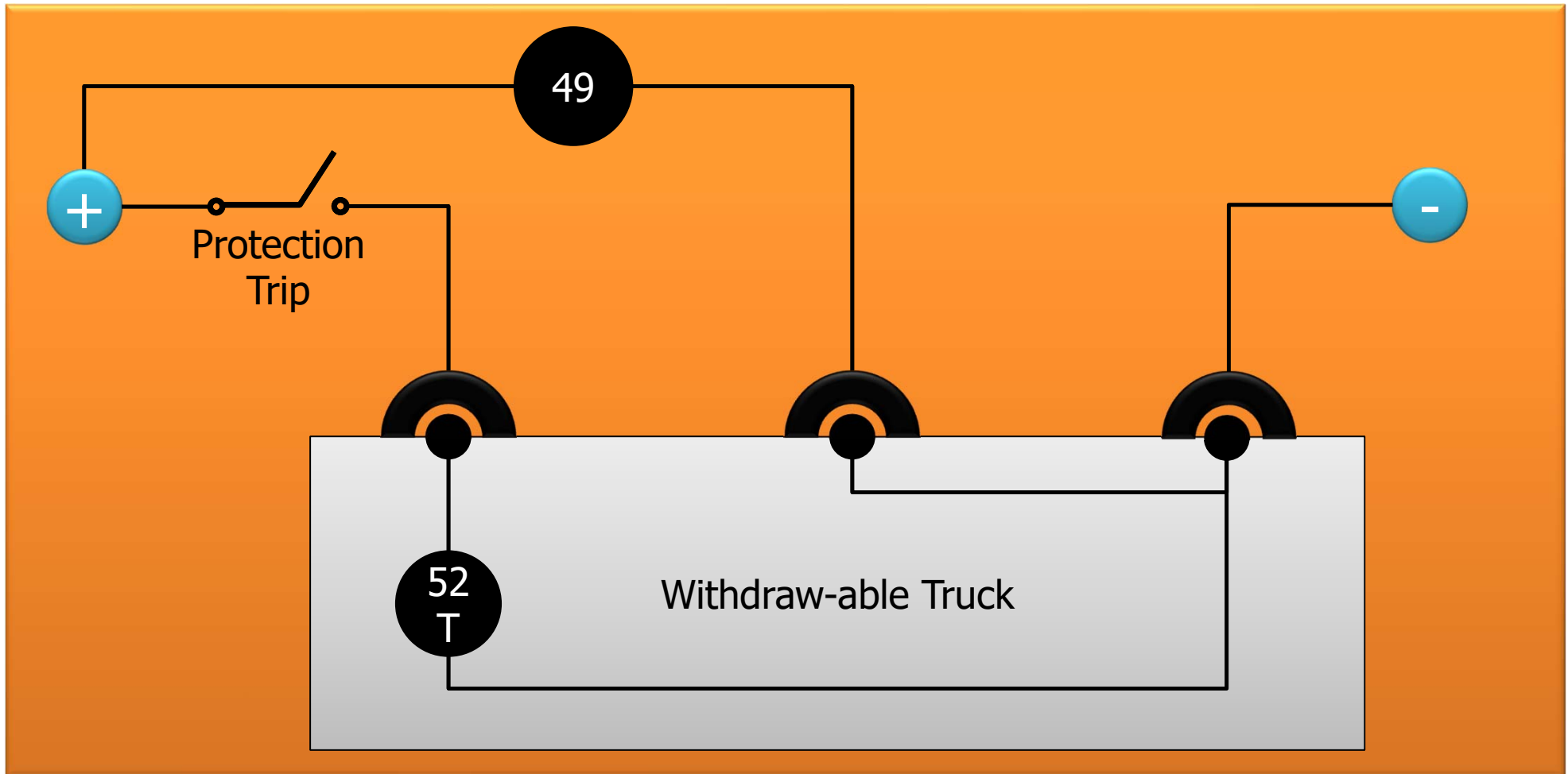

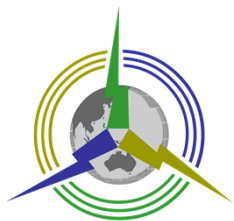

Trip Supply Monitor

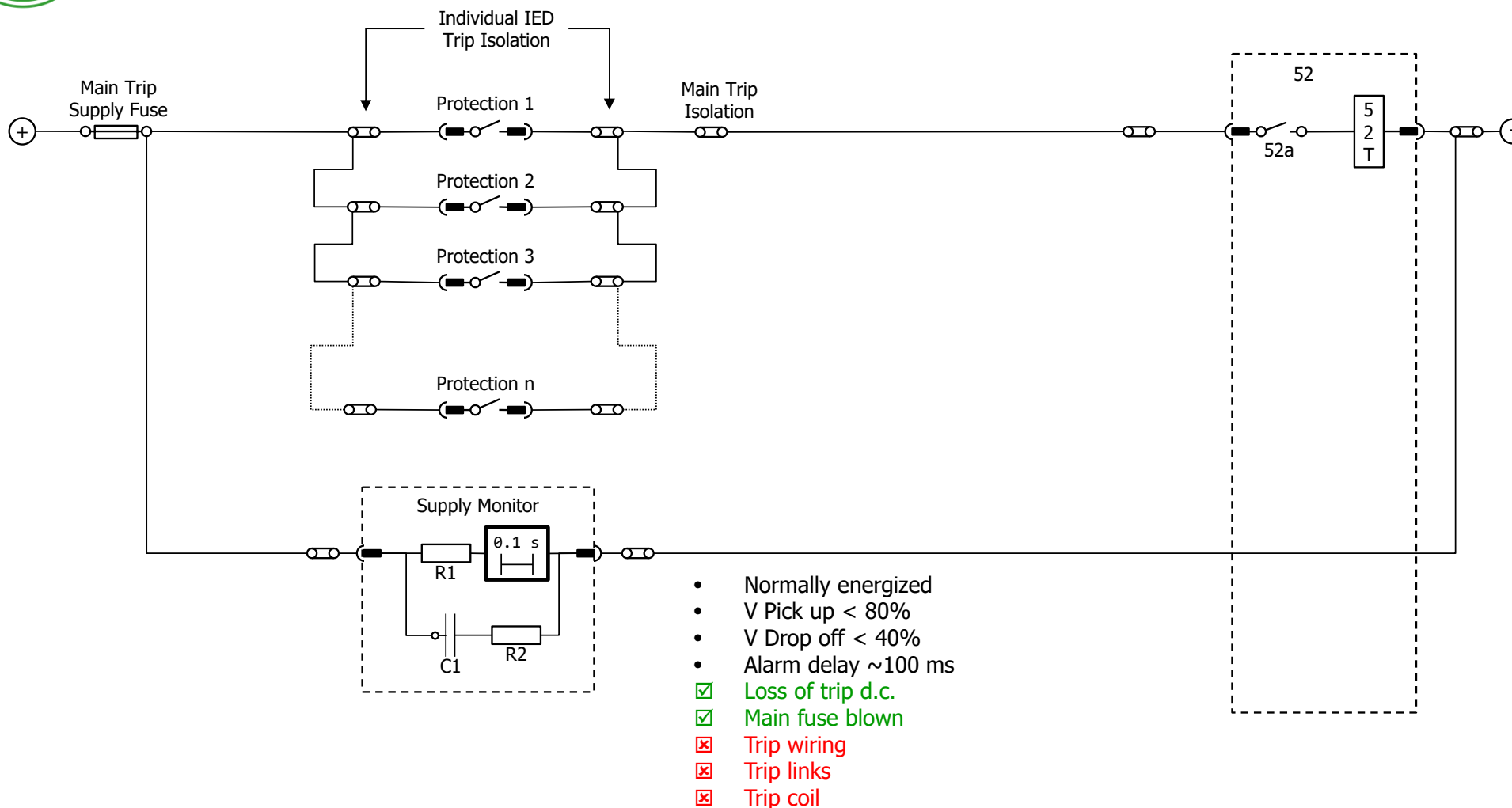

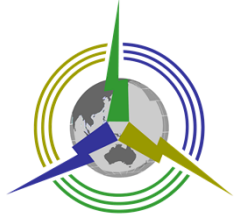

COIL-BASED TRIP CIRCUIT SUPERVISION



General Trip Circuit: 'X' Protection

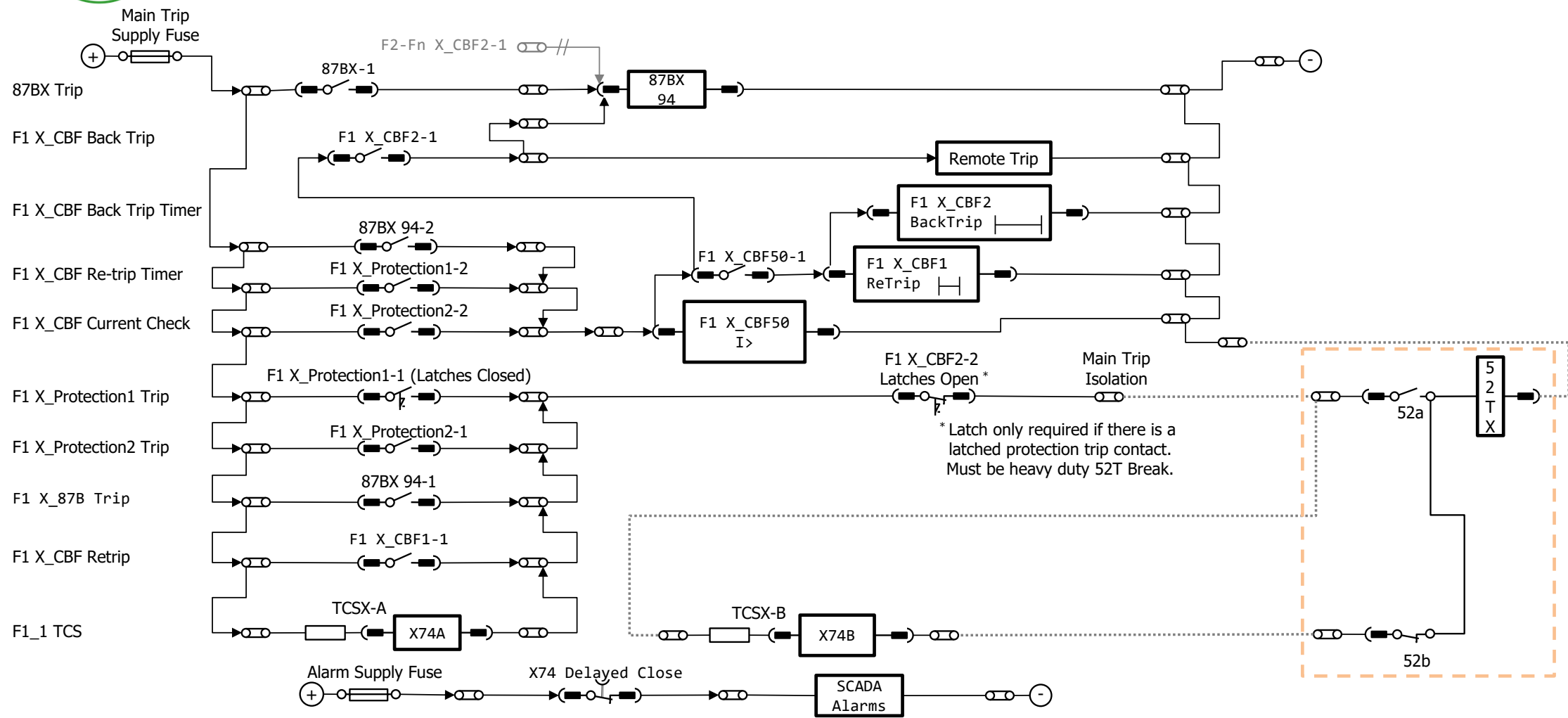

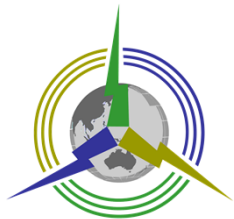

Supervised Wiring: CB Closed

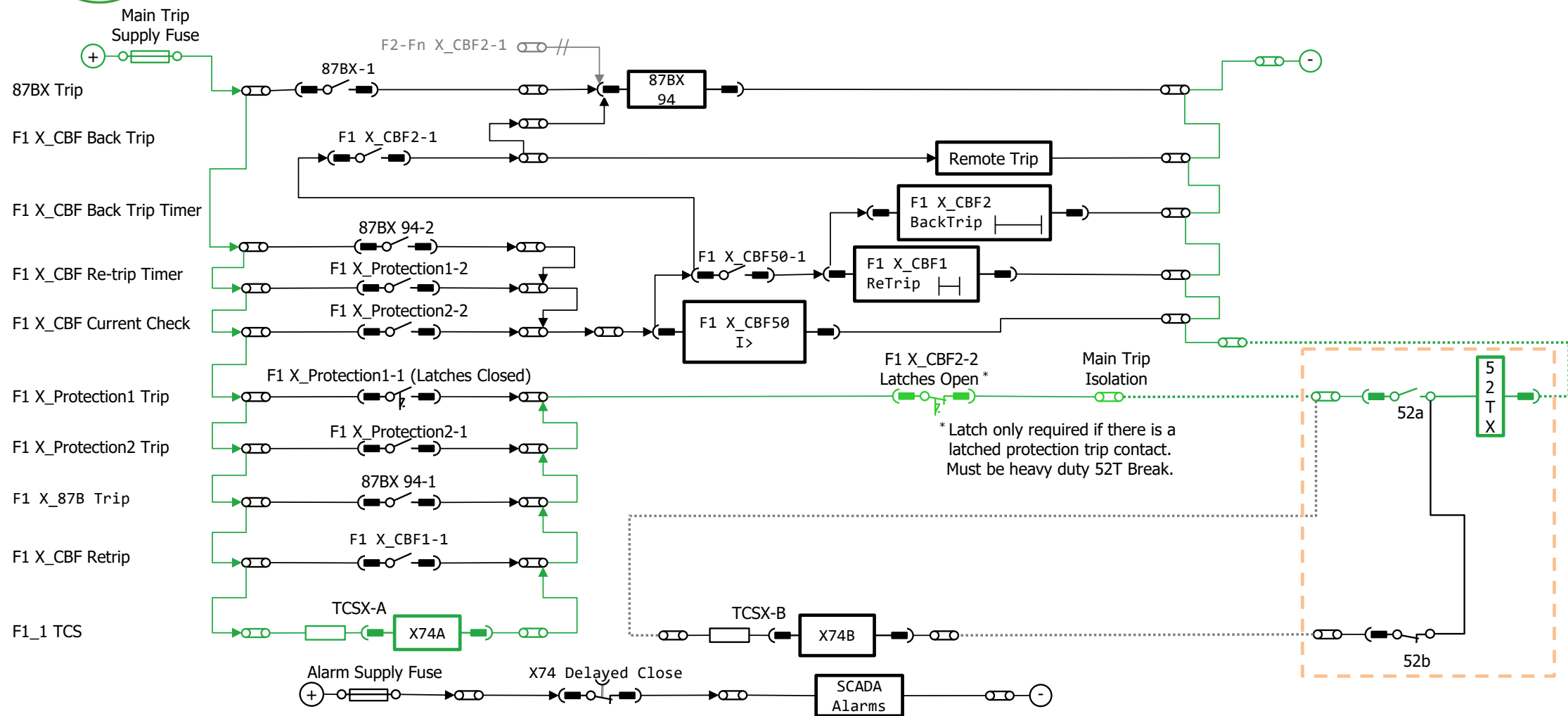

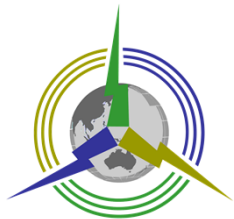

Supervised Wiring: Pre-Close, CB Open

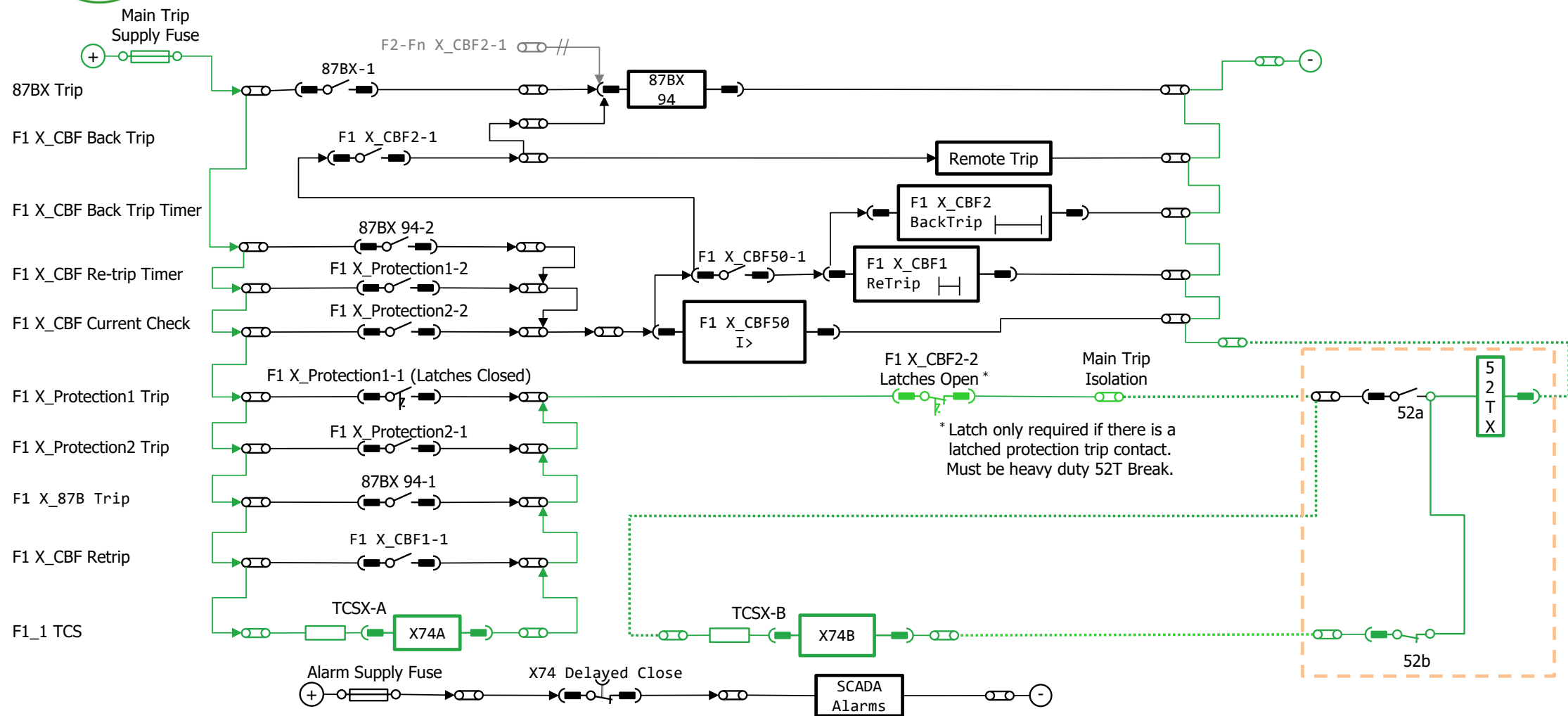

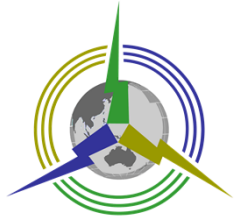

- ✦ TCS cannot “supervise” correct mechanical operation of 52a or 52b
 - ✦ Only confirms if the contact is in the correct position relative to the CB at that instant
 - ✦ Cannot predict contact will change state when CB changes state
- ✦ TCS is no basis of NOT doing regular CB maintenance

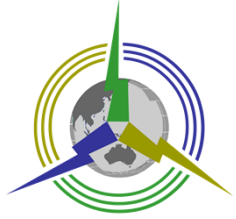

Incorrect TCS Location (1)

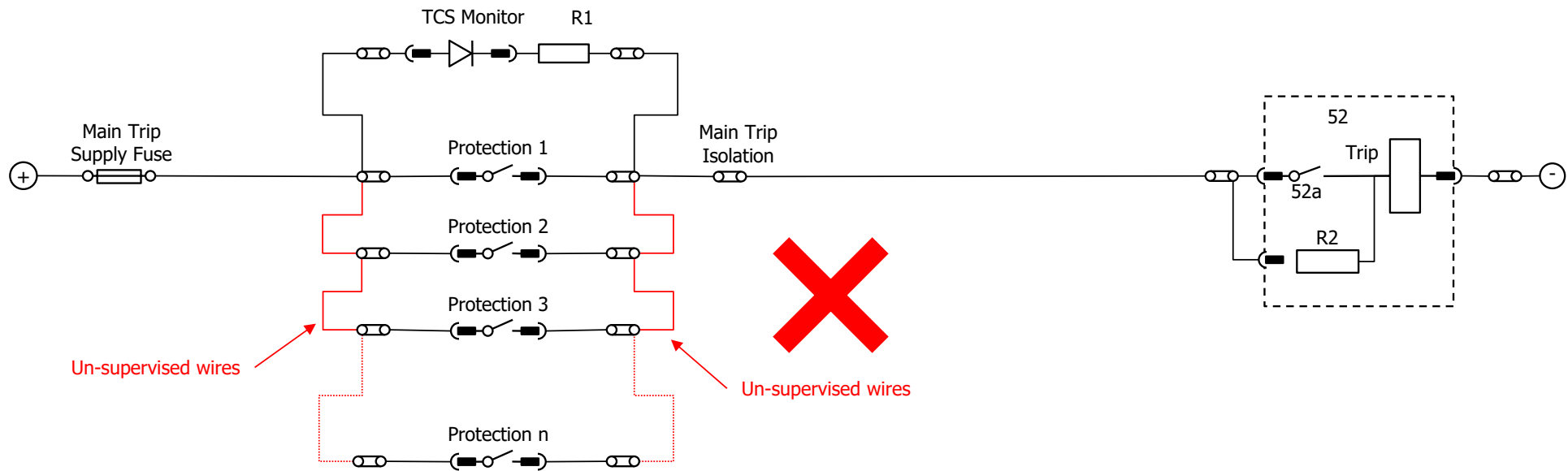

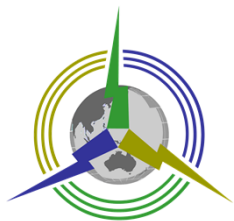

Incorrect TCS Location (2)

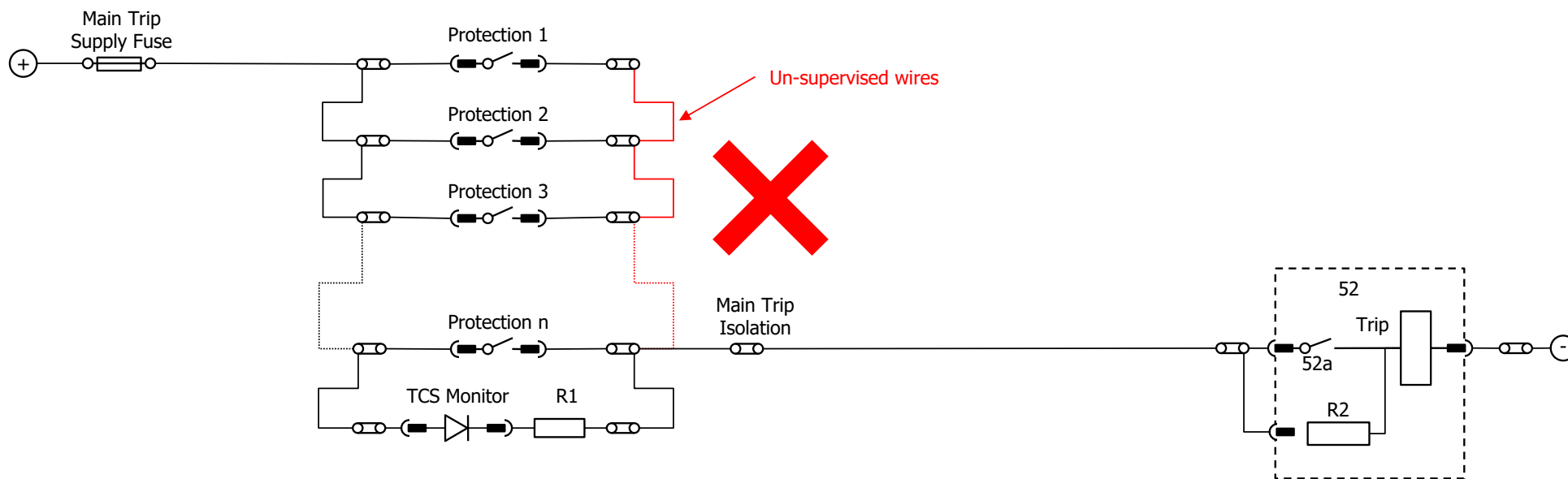

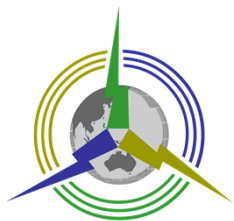

Correct TCS Location

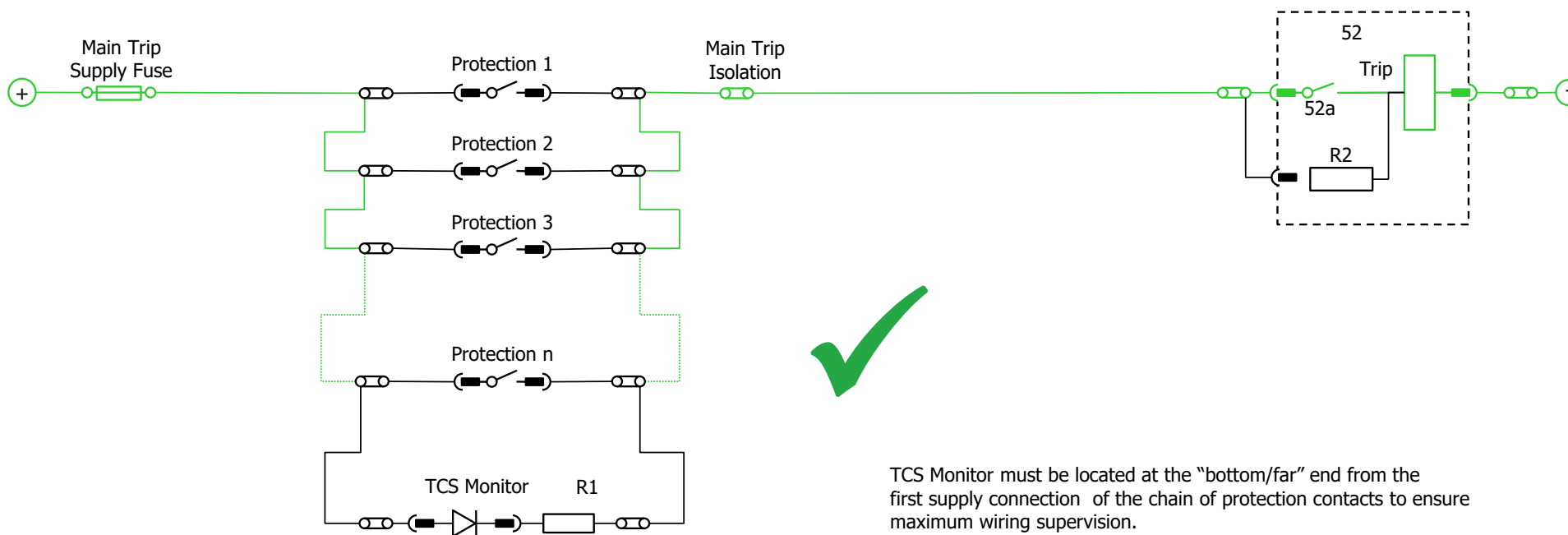

TCS Monitor must be located at the "bottom/far" end from the first supply connection of the chain of protection contacts to ensure maximum wiring supervision.

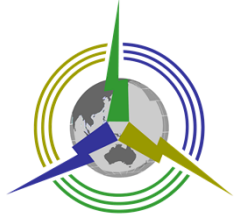

DIFFERENT SCHEMES



TCS for CB Closed

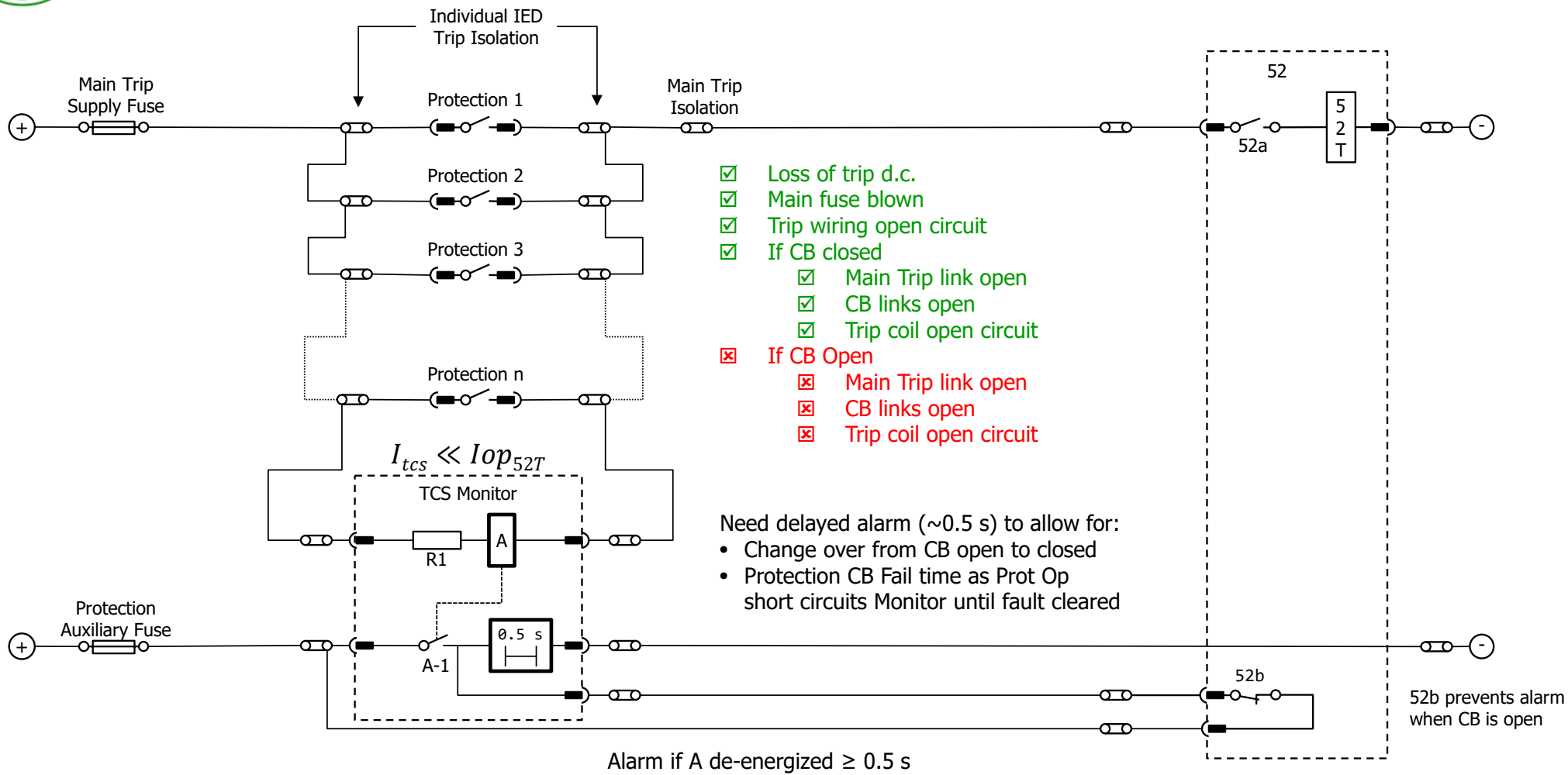



Full Relay-Monitor TCS

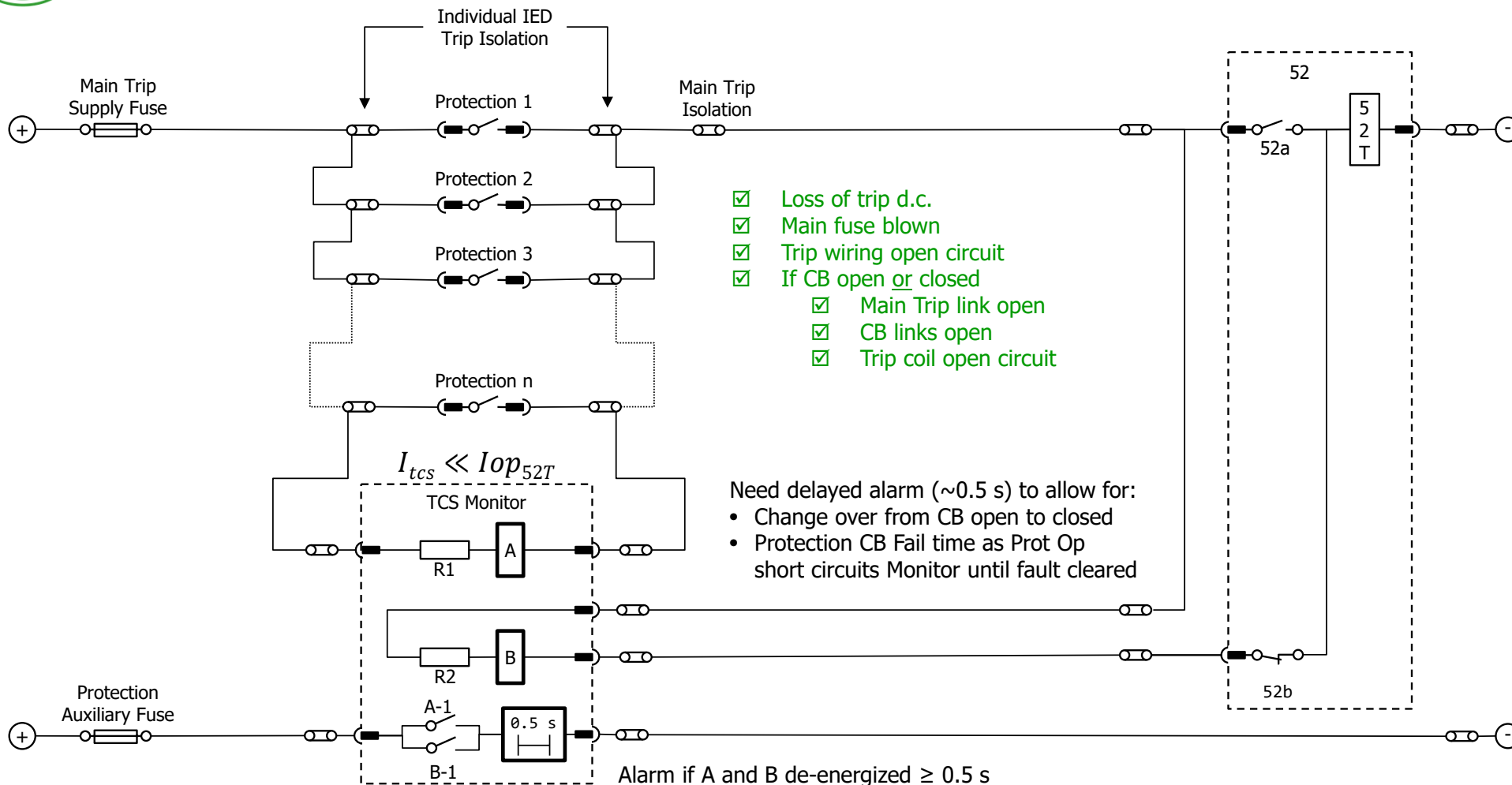



Full TCS: CB Closed

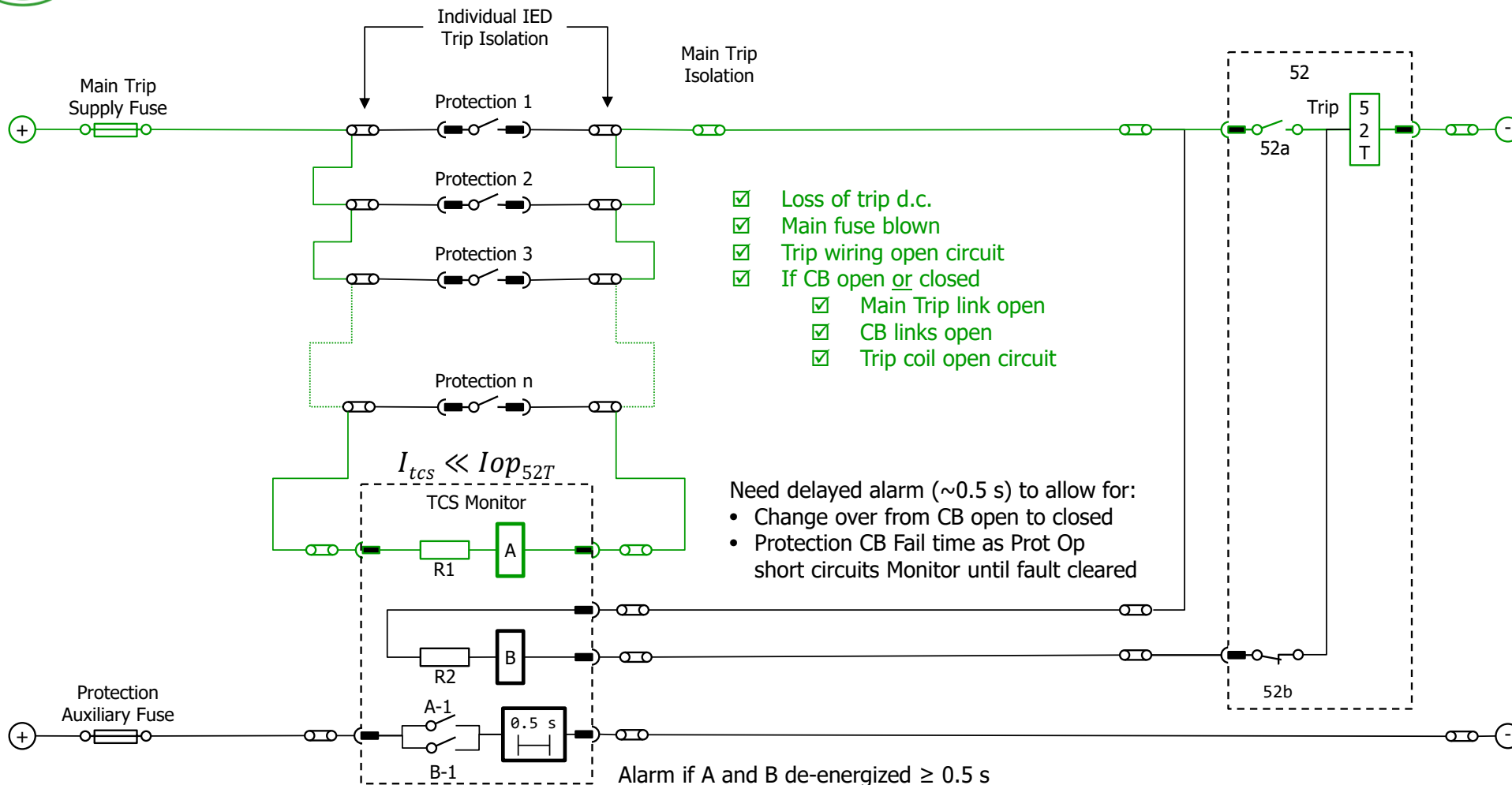

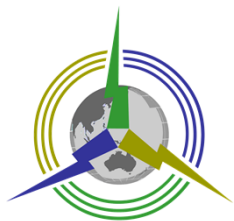

Full TCS: CB closed, Prot operated

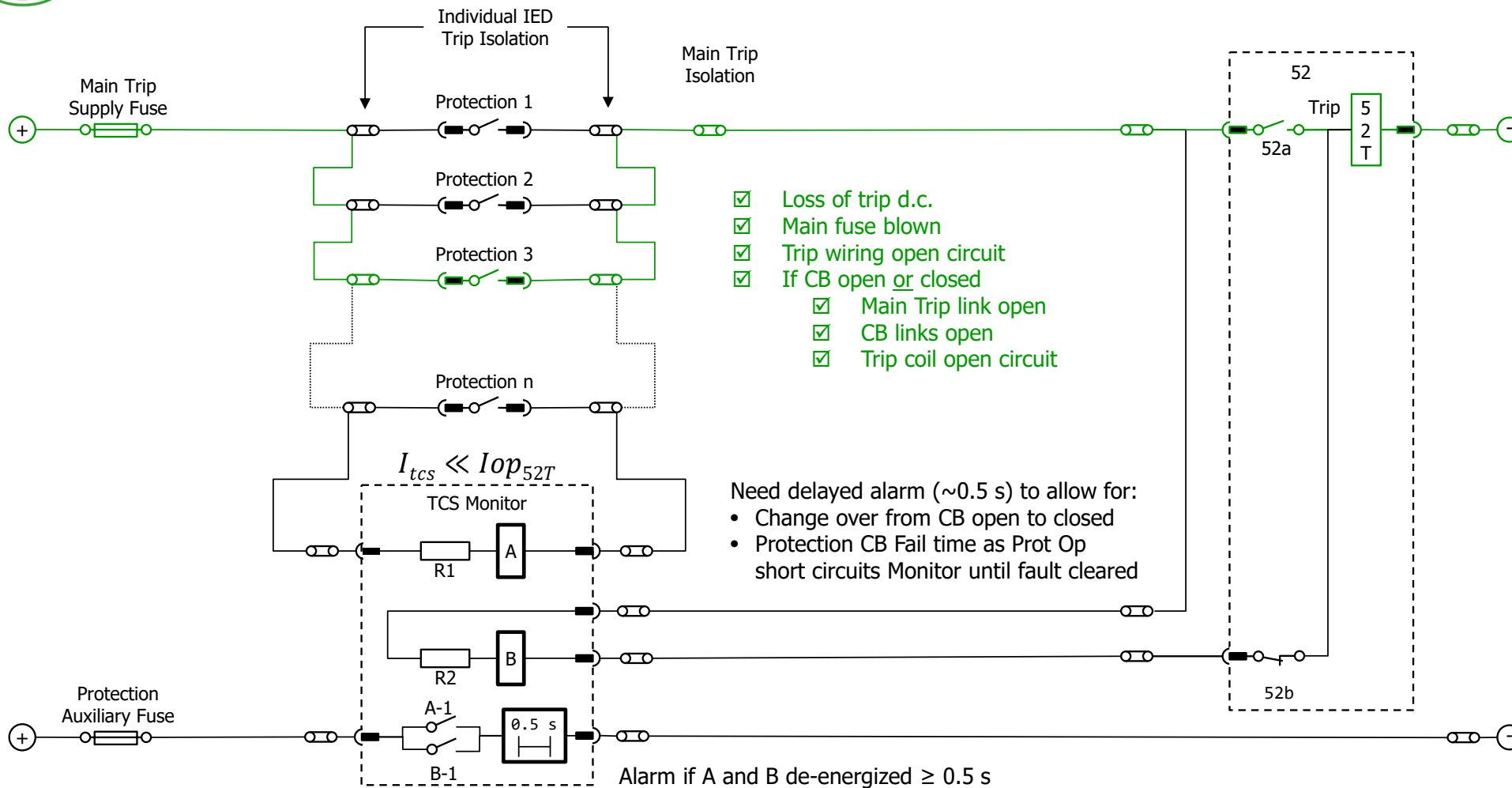

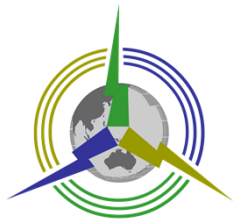

Full TCS: CB Open

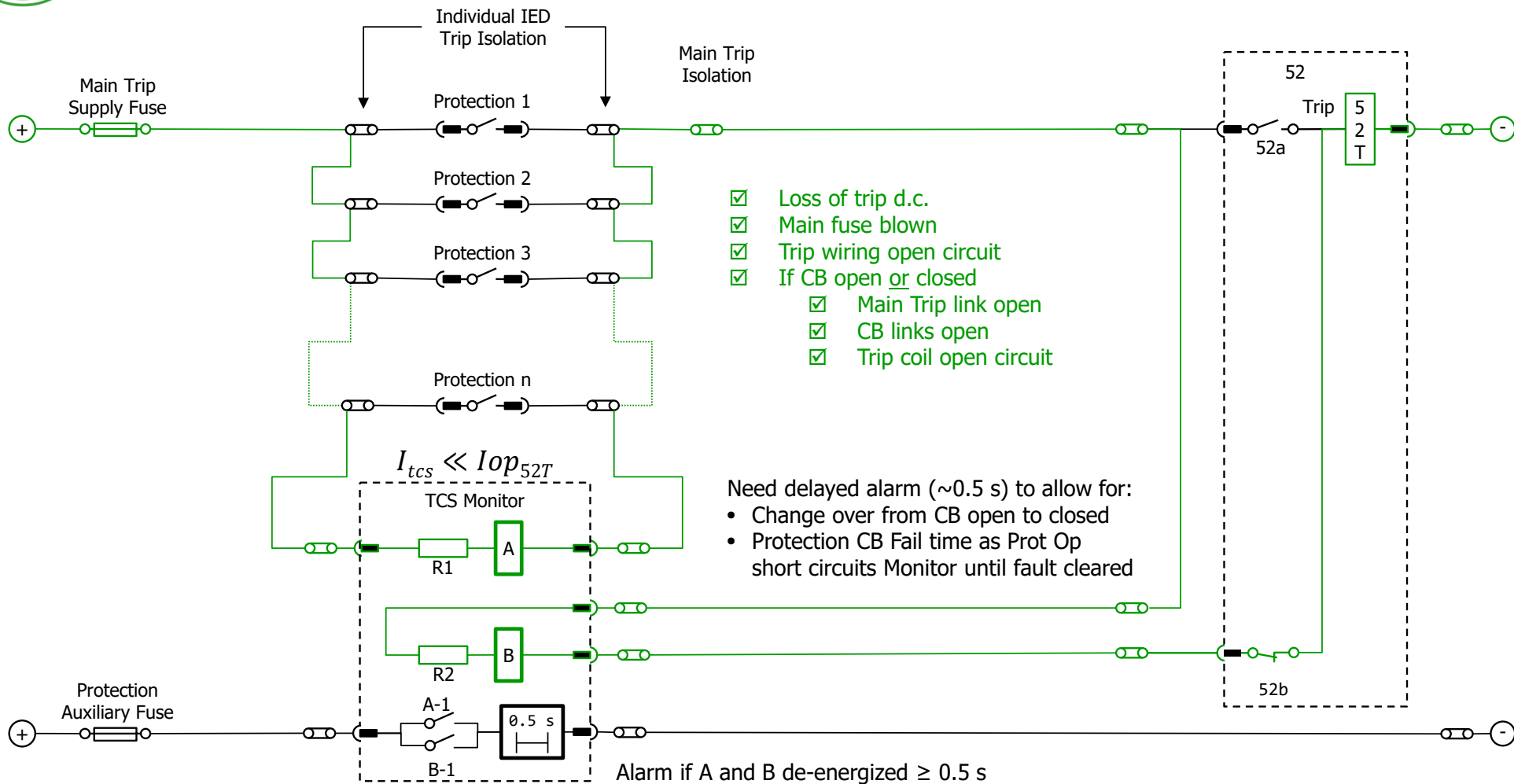

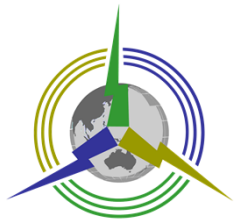

Full Opto-Monitor TCS: Two Opto

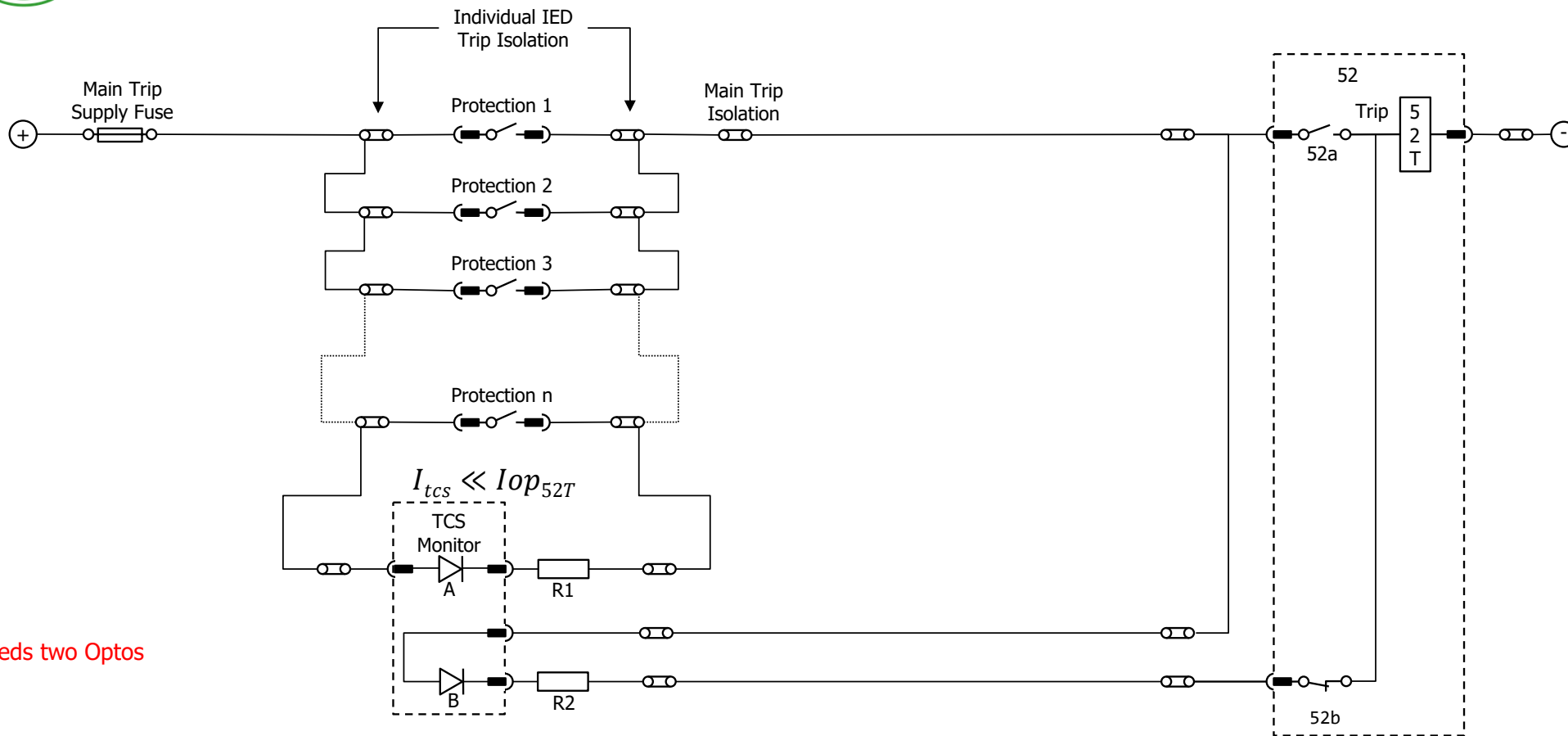

Needs two Optos

Alarm if A and B de-energized ≥ 0.5 s

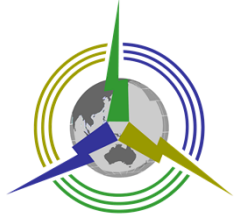

Full Opto-Monitor TCS: One Opto

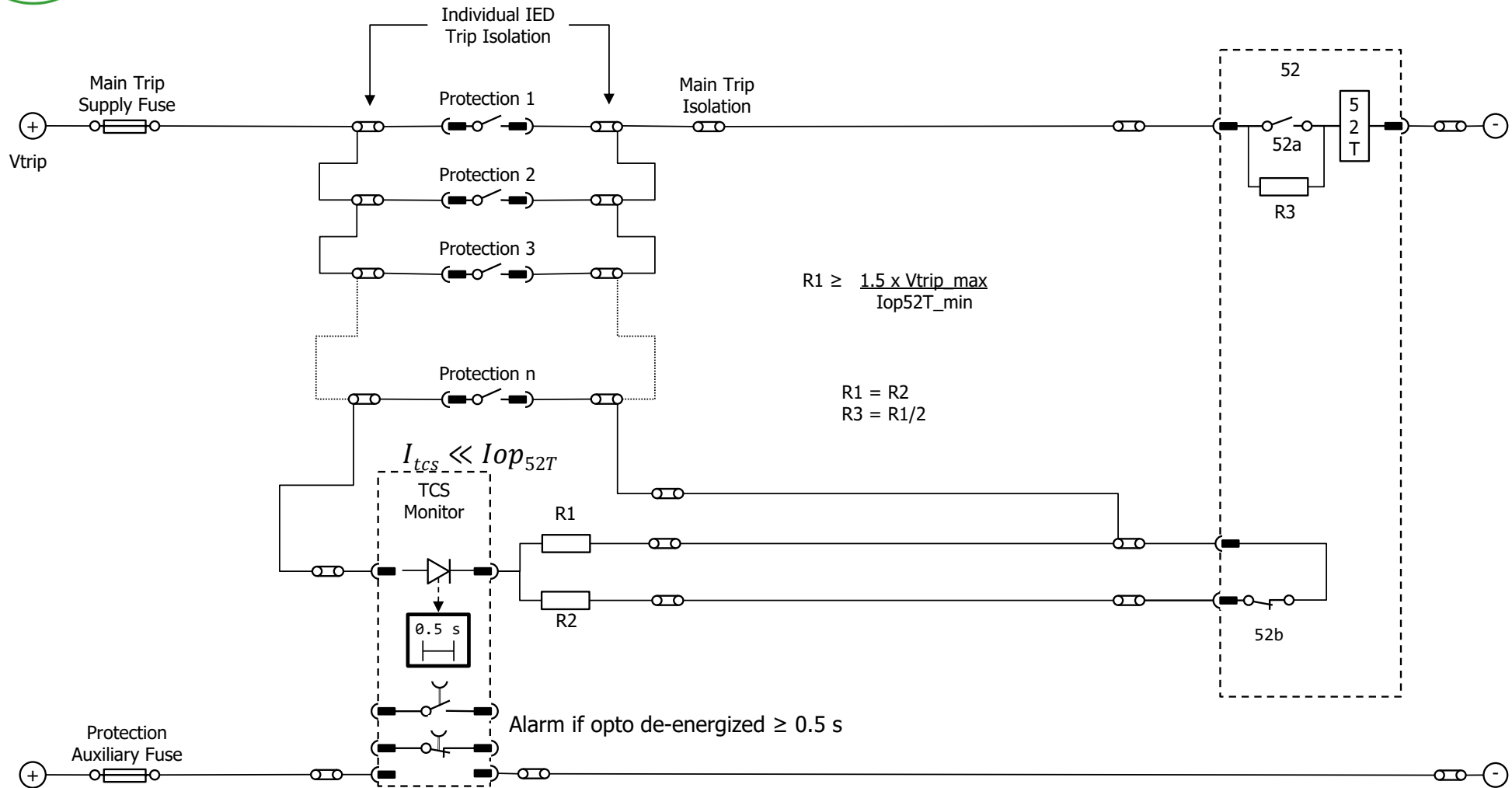

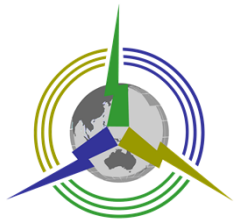

One TCS Opto: CB Closed

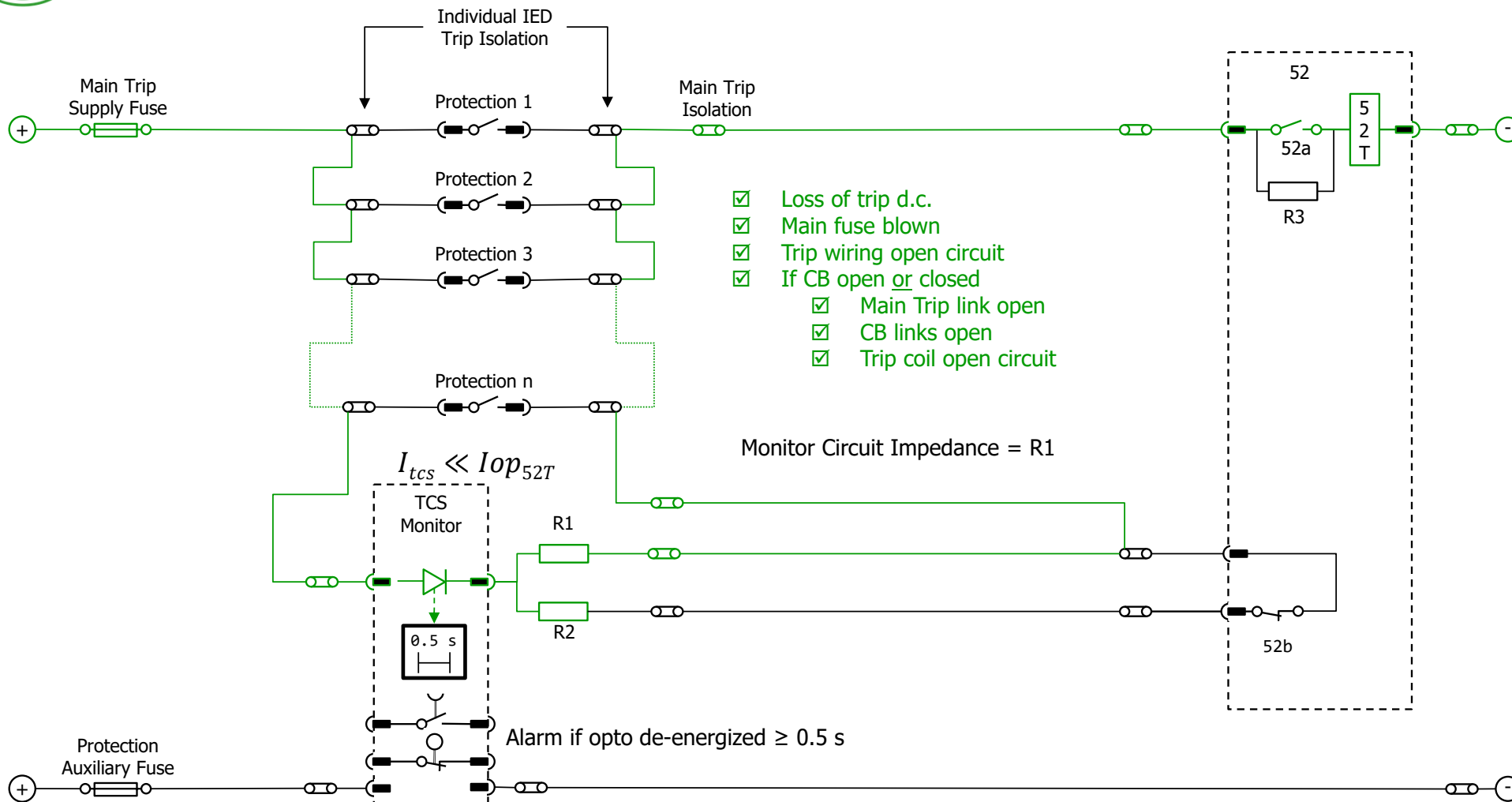



One TCS Opto: CB Open

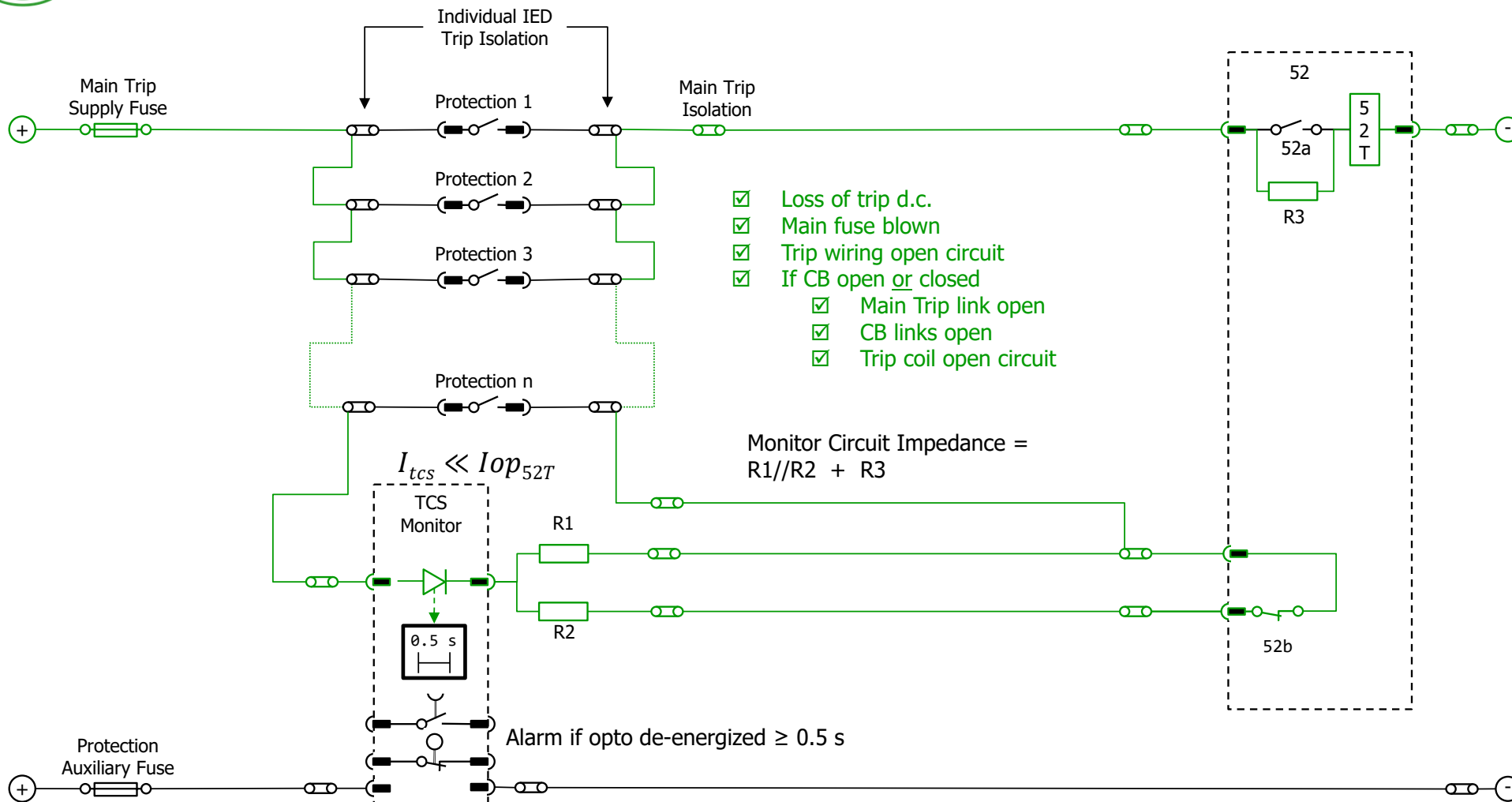



Single Opto, Single Wire Single CB Aux Contact Full TCS

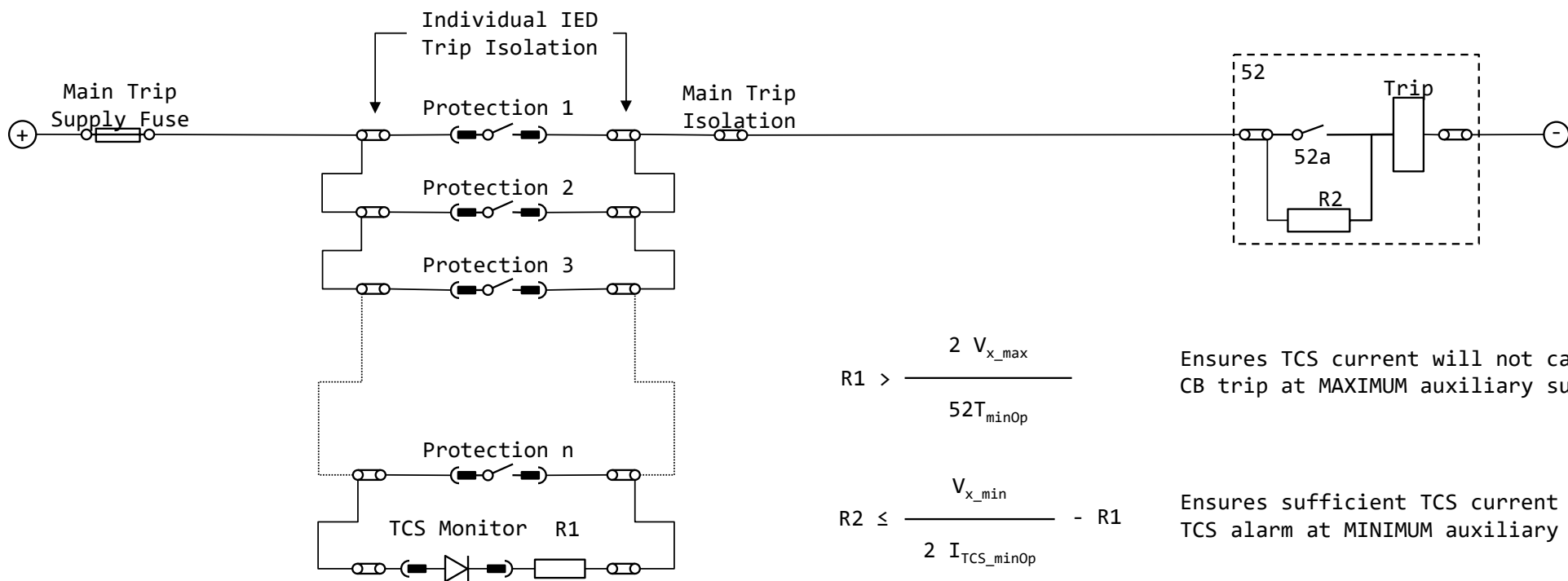

$$R1 > \frac{2 V_{x_max}}{52T_{minOp}}$$

Ensures TCS current will not cause CB trip at MAXIMUM auxiliary supply

$$R2 \leq \frac{V_{x_min}}{2 I_{TCS_minOp}} - R1$$

Ensures sufficient TCS current to prevent TCS alarm at MINIMUM auxiliary supply

Note: TCS is normally energised
When protection operates, TCS is short circuited and will therefore de-energise

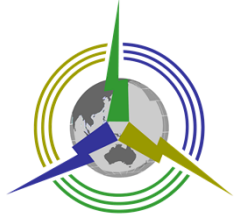

But ... Is this really what you want?

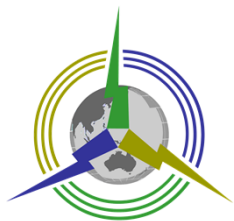

CB Fail Triggered

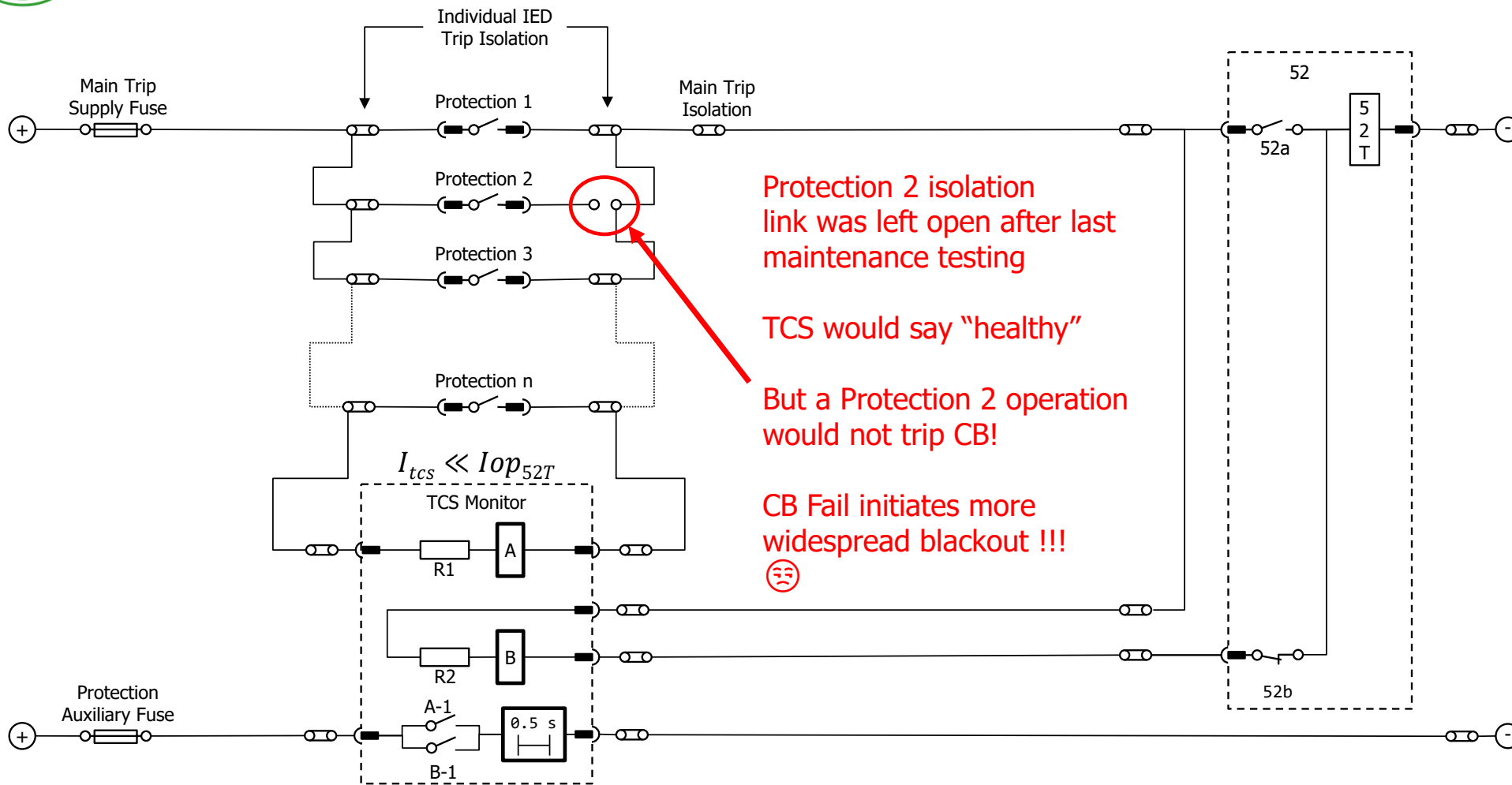



CB Fail Local Re-trip

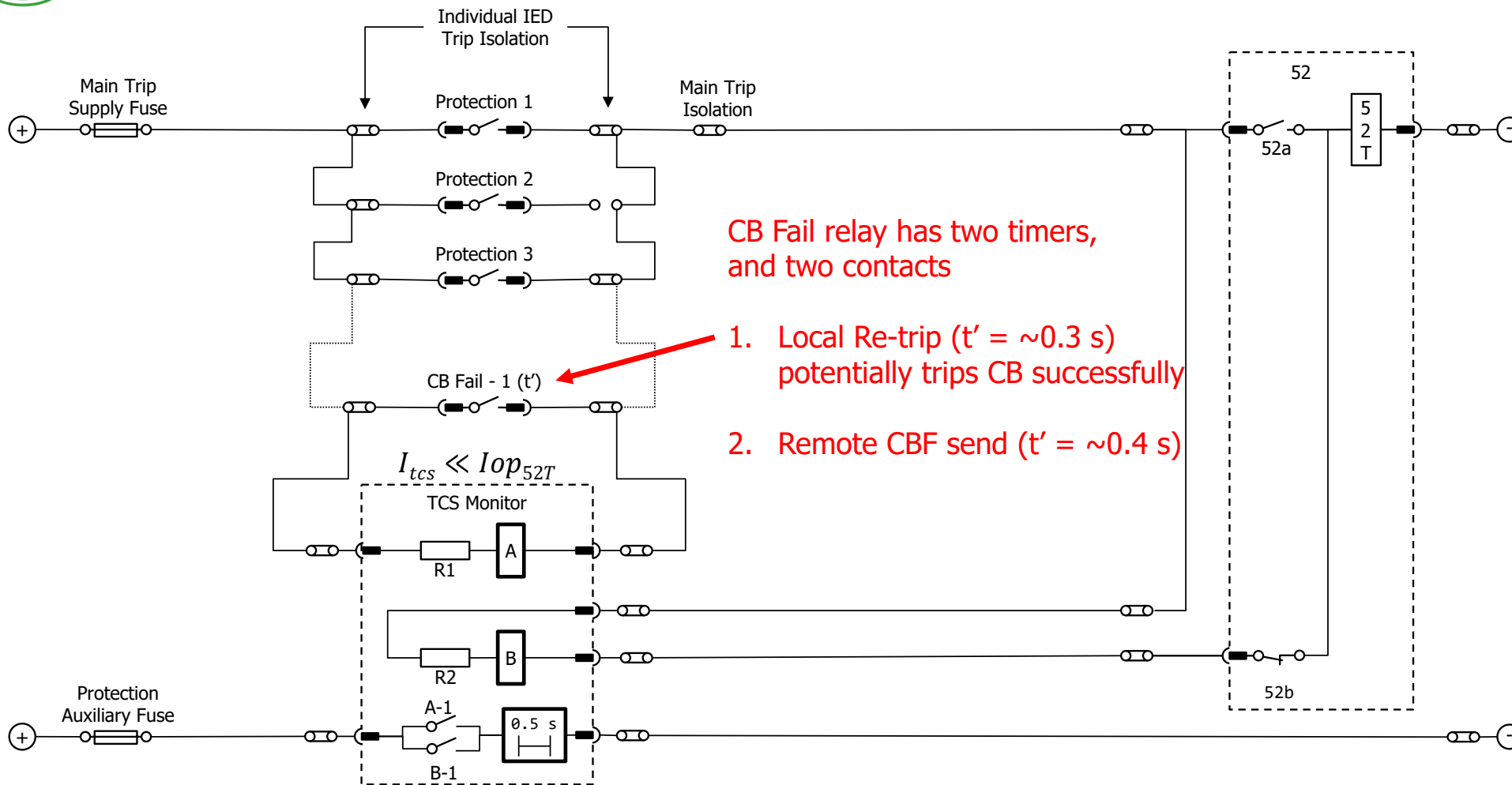

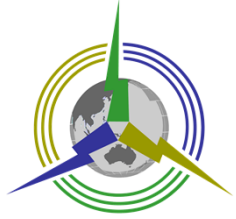

E-mail: rgh@rodhughesconsulting.com
Office: +61 8 7127 6357
Mobile: +61 419 845 253
Web: www.rodhughesconsulting.com
Skype: rodhughes-consult
LinkedIn: <https://www.linkedin.com/in/rodneighughes>
Address: PO Box 757
Blackwood
SA 5051
Australia
A.B.N. 64 137 442 089